

We build a better future

Robex
16-9

Equipped with Tier 3a engine



*Photo may include optional equipment.

Pleasure works

An operator, who takes pleasure in his work, does a better job. That is why we at Hyundai Heavy Industries do everything we can to make that happen. We merged operator preference, fast precision and lasting performance into a quality product. Hyundai's 9 series earthmoving equipment simply makes time fly, makes pleasure work!



*Photo may include optional equipment.

Machine Walk-Around

Rugged Upper and Lower Frame

The structure of the upper frame is designed to absorb high stress and to resist inherent external influences. A reinforced box section track frame provides exceptional strength and longer service life to withstand tough working conditions.

Compact design

A compact design allows the operator to work in confined areas, as urban and road construction. R16-9's variable undercarriage provides maximum stability while working and minimum passage width for transporting the machine, in order to have full flexibility and efficiency on any restricted jobsite.

Engine Technology

Well proven and reliable Mitsubishi L3E engine, complying with current Tier 3A emission regulation. This engine provides efficient fuel combustion and reduced noise.

Efficient Control System

Control devices are ergonomically located for improved operator comfort and higher productivity. A safety lever on the left side console is installed to prevent exiting the cabin with active hydraulic control levers.

Advanced Hydraulic System

The hydraulic system of the R16-9 is designed for fast operation combined with high controllability.

Comfortable and Durable Canopy

Canopy frame meets international TOPS-, ROPS-, FOPS-standards ensuring operator's safety.

Operator's Convenience

Suspension seat, ergonomically designed joysticks with wrist rests and plenty of leg room help to reduce operator's fatigue. An array of indicators and gauges are displayed on the monitor, which keeps the operator aware of the status of the machine. The monitoring system displays seven warning indicators, water temperature gauge, fuel gauge and hour meter.

Easy to Maintain

With open access of doors, covers and engine hoods, air cleaner and centralized grease fittings the machine is a pleasure to maintain.

Extended Life of Components

Long-life hydraulic filters, long-life hydraulic oil, long-lasting shims and long-lasting bushes are reducing operation costs.

Preference

An operator, who sets his machine to his needs, takes pleasure in his work. 9 Series respects operator preference with regards to comfort, ease-of-use and controllability. Operators can fully customize their work environment and operating preferences to fit their individual needs.



*Photo may include optional equipment.



Dashboard

The dashboard of the R16-9 indicates the status of the machine like warnings of engine oil pressure, battery charge, engine coolant temperature and fuel gauges.

Comfortable Operating Space

In the 9 series canopy you can easily adjust the seat and wrist rests settings to suit your preferred comfort level.

1. The pedals (travel - boom offset - attachment) are installed in a convenient position and can be folded in to gain extra foot space.
2. Different sizes of cup holders.
3. Adjustable wrist rests to increase operator's comfort..
4. Ergonomically located control devices for higher production and better efficiency.



Operator Comfort

The left and right joysticks are ergonomically placed for convenient operation. Pilot operated levers control the dozer blade and track extension. Easy-to-access control switches on the left side console improve operating comfort.



A tiltable left-side console offers the operator better access to the cab. A safety lock system is installed to prevent exiting the cabin with active hydraulic control levers. When the safety lever and left side console are positioned upright, hydraulic functions are deactivated.

Stressless

Work is stressful enough; your working environment should be stressless. Hyundai R16-9 provides an adjustable suspension seat, wrist rests, ergonomically designed joysticks and plenty of space to minimize the stress of the operator.



Precision

An operator, who feels his machine respond smoothly, takes pleasure in his work. 9 Series delivers fast precision by combining smoother hydraulics with wider view and less stress. Innovative hydraulic system technologies make the R16-9 excavator fast, smooth and easy to control.



*Photo may include optional equipment.

Hydraulic System Improvements

Optimized matching between joysticks and main control valve improves fine control and offers smooth operation. Newly improved features include arm flow summation system and boom holding system, in order to save energy, prevent against cavitation, increase speed and to avoid the drop of attachments in neutral condition.

Offset Boom

With an offset function of the boom from 60° to the left side and 60° to the right side, the zero-tail machine is even more flexible to use on narrow jobsites.



Structural Strength

The R16-9 canopy structure is designed with slimmer but stronger tubing for more safety and better visibility. Low-stress and high strength steel is welded to form a strong and stable lower frame. Structural durability is analyzed and tested by way of FEM-analysis (Finite Elements Method) and long-term durability tests.

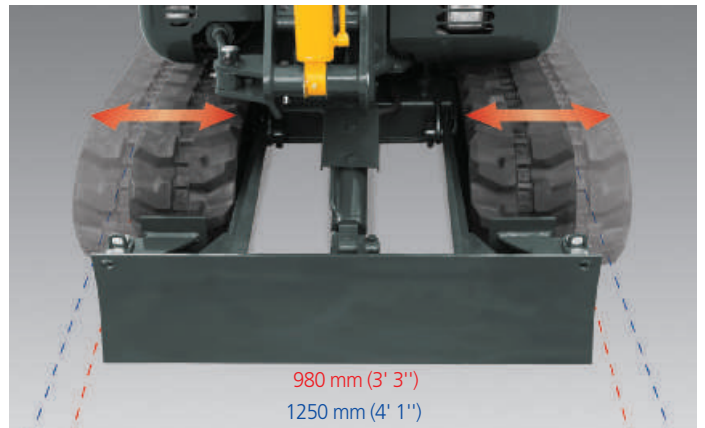

Hydraulic Adjustable Undercarriage

The track width of our R16-9 can be adjusted between 980 mm and 1,250 mm (3'3"~4'1"). The operator can adapt the blade width easily by removing pins. Rubber tracks are fitted standard to protect any surface.



Mitsubishi L3E

The Mitsubishi L3E engine provides maximum power, high reliability and optimum fuel economy, complying with the current EU Stage IIIa or Tier 3a emission regulation.

Profitability

An owner, who knows his machine saves money, takes pleasure in owning it. 9 Series excavators contribute to your business as a time, fuel, spare-part and cost saving earthmoving solution.



*Photo may include optional equipment.



Easy Maintenance Access

The R16-9 was built with accessibility in mind. All doors, covers and hoods are designed for full open accessibility. The R16-9 offers plenty of space to complete regular maintenance.



Easy to Change Air Cleaner

The R16-9 is equipped with a durable plastic air cleaner, designed for easy maintenance.

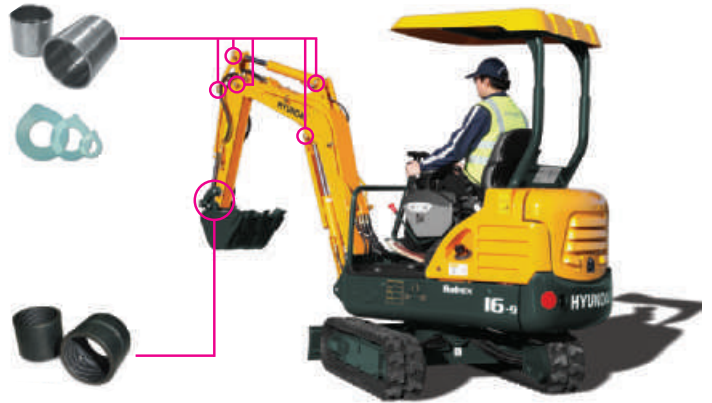

Extended Life of Components

By adopting long-life hydraulic filters (1000 hrs) and long-life hydraulic oil (5000 hrs) operation costs are reduced. Oil change intervals are extended to 250 operating hours because self-lubricating bushes and resin shims are applied.



Centralized Grease Fittings

Centralized grease fittings for faster and easier maintenance.

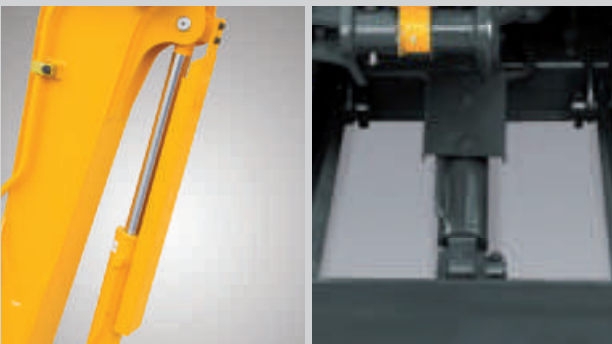

Cylinder Covers

Cylinders of boom and dozer blade are provided with covers for extra protection.

Specifications

ENGINE

MODEL	MITSUBISHI L3E		
Type	4 Cycle Diesel engine, 3 cylinders in line, water cooled		
Rated flywheel horse power			
SAE	J1995 (gross)	16.8 hp (12.5 kw) / 2,300 rpm	
	J1349 (net)	16.2 hp (12.1 kw) / 2,300 rpm	
DIN	627 1/1 (gross)	17 ps (12.5 kw) / 2,300 rpm	
	627 1/1 (net)	16.5 ps (12.1 kw) / 2,300 rpm	
Max. torque	5.4 kgf.m (39 lbf.ft) at 1,800 rpm		
Bore x stroke	76 mm (2.99") x 70 mm (2.76")		
Piston displacement	952 cc (58.1in ³)		
Batteries	12V, 80 AH		
Starting motor	12V - 1.7 kW		
Alternator	12V - 40 A		

HYDRAULIC SYSTEM

Main pump	
Type	variable displacement piston pumps
Rated flow	2 x 17.0 l/min (4.5 US gpm / 3.7 UK gpm)
Pilot pump	Gear pump
Hydraulic motors	
Travel	Two speed axial piston motor with counter balance valve
Swing	Axial piston motor
Relief valve setting	
Implement circuits	210 kgf/cm ² (2,990 psi)
Travel circuit	210 kgf/cm ² (2,990 psi)
Swing circuit	170 kgf/cm ² (2,420 psi)
Pilot circuit	30 kgf/cm ² (430 psi)
Service valve	Installed

HYDRAULIC CYLINDERS

No. of cylinder - bore x stroke	
Boom	60 x 465 mm (2.4" x 18.3")
Arm	60 x 400 mm (2.4" x 15.7")
Bucket	55 x 345 mm (2.2" x 13.6")
Boom swing	55 x 355 mm (2.2" x 14.0")
Dozer blade	65 x 93 mm (2.6" x 3.7")
Adjustable undercarriage	50 x 270 mm (2.0" x 10.6")

OPERATOR'S CAB

Noise Levels (dynamic value)	
Outside cabin - LwA	93 dB
Inside cabin - LpA	82 dB

COOLANT & LUBRICANT CAPACITY

(refilling)	liter	US gal	UK gal
Fuel tank	25	6.6	5.5
Engine coolant	4.2	1.1	0.9
Engine oil	4.2	1.1	0.9
Hydraulic tank	20	5.3	4.4

TRAVEL LEVERS

Traveling and steering: Two levers with foldable pedals.

HYDRAULIC CONTROLS

Type	
Pilot control	Two joysticks with one safety lever (LH): Swing and arm, (RH): Boom and bucket with horn (ISO)
Engine throttle	Mechanical, cable type

SWING SYSTEM

Swing motor	Axial piston motor
Swing reduction	Planetary gear reduction
Swing circuit lubrication	Lubricated with drain oil
Swing speed	9.3 rpm

DRIVES & BRAKES

Max. travel speed (high/low)	4.1 km / 2.2 km (2.5 mph) / (1.4 mph)
Maximum traction force	1.55 ton
Maximum gradeability	30°
Parking brake	Multi wet disc

DIGGING FORCE (ISO)

Bucket	1,540 kgf
	15.1 kN
	3,400 lbf
Arm	960 kgf
	9.4 kN
	2,120 lbf

WEIGHT (APPROXIMATE)

Operating weight, including 1,800 mm (5' 11") boom; 960 mm (3' 2") arm, SAE heaped 0.04 m³ (0.05 yd³) excavator bucket, lubricant, coolant, full fuel tank, hydraulic tank and the standard equipment.

Shoe Width	Rubber shoe 230 mm (9")
Operating weight (canopy)	1,650 kg (3,640 lb)
Ground pressure (canopy)	0.27 kg/cm ² (3.84 psi)

UNDERCARRIAGE

Center frame is integrally welded with reinforced box-section track frames. The undercarriage includes lubricated rollers, track adjusters with shock absorbing springs, sprockets and rubber tracks.

Track frame	Adjustable undercarriage
No. of track roller on each side	3 EA

LIFTING CAPACITIES R16-9



Boom : 1.80 m (5' 11") / Arm : 0.96 m (3' 2") / Bucket : 0.04 m³ (0.05 yd³) SAE heaped / Dozer blade up, track extended, 230 mm (9") rubber track.

Load point height m (ft)		Load radius						At max. reach		
		2.0 m (6.6 ft)		2.5 m (8.2 ft)		3.0 m (9.8 ft)		Capacity		Reach
										m (ft)
3.0 m (9.8 ft)	kg lb							300 660	270 600	2.72 (8.9)
2.5 m (8.2 ft)	kg lb			*320 *710	310 680			220 490	200 440	3.22 (10.6)
2.0 m (6.6 ft)	kg lb			330 730	300 660	240 530	220 490	180 400	170 370	3.52 (11.5)
1.5 m (4.9 ft)	kg lb	*460 *1010	420 930	320 710	290 640	240 530	220 490	170 370	150 330	3.69 (12.1)
1.0 m (3.3 ft)	kg lb	450 990	400 880	310 680	280 620	230 510	210 460	160 350	140 310	3.76 (12.3)
0.5 m (1.6 ft)	kg lb	420 930	380 840	300 660	270 600	220 490	200 440	160 350	140 310	3.74 (12.3)
Ground Line	kg lb	410 900	370 820	290 640	260 570	220 490	200 440	160 350	150 330	3.62 (11.9)
-0.5 m (-1.6 ft)	kg lb	410 900	360 790	290 640	260 570	220 490	200 440	180 400	170 370	3.39 (11.1)
-1.0 m (-3.3 ft)	kg lb	410 900	370 820	290 640	260 570	220 510	200 440	230 510	200 440	3.00 (9.8)
-1.5 m (-4.9 ft)	kg lb	430 950	380 840							
-2.5 m (-8.2 ft)	kg lb							*230 *510	210 460	3.14 (10.3)

Boom : 1.80 m (5' 11") / Arm : 0.96 m (3' 2") / Bucket : 0.04 m³ (0.05 yd³) SAE heaped / Dozer blade down, track extended, 230 mm (9") rubber track.

Load point height m (ft)		Load radius						At max. reach		
		2.0 m (6.6 ft)		2.5 m (8.2 ft)		3.0 m (9.8 ft)		Capacity		Reach
										m (ft)
3.0 m (9.8 ft)	kg lb							*300 *660	290 640	2.72 (8.9)
2.5 m (8.2 ft)	kg lb			*320 *710	*320 *710			*310 *680	210 460	3.22 (10.6)
2.0 m (6.6 ft)	kg lb			*340 *750	320 710	*340 *750	230 510	*310 *680	180 400	3.52 (11.5)
1.5 m (4.9 ft)	kg lb	*460 *1010	450 990	*400 *880	310 680	*370 *820	230 510	*320 *710	160 350	3.69 (12.1)
1.0 m (3.3 ft)	kg lb	*660 *1460	420 930	*480 *1060	300 660	*410 *900	220 490	*330 *730	150 330	3.76 (12.3)
0.5 m (1.6 ft)	kg lb	*820 *1810	400 880	*560 *1230	290 640	*450 *990	220 490	*340 *750	150 330	3.74 (12.3)
Ground Line	kg lb	*880 *1940	390 860	*610 *1340	280 620	*470 *1040	210 460	*350 *770	160 350	3.62 (11.9)
-0.5 m (-1.6 ft)	kg lb	*860 *1900	390 860	*610 *1340	280 620	*460 *1010	210 460	*360 *790	180 400	3.39 (11.1)
-1.0 m (-3.3 ft)	kg lb	*770 *1700	390 860	*550 *1210	280 620	*550 *1210	280 620	*350 *770	220 490	3.00 (9.8)
-1.5 m (-4.9 ft)	kg lb	*560 *1230	400 880							
-2.5 m (-8.2 ft)	kg lb							*230 *510	220 490	3.14 (10.3)

- Lifting capacity is based on SAE J1097, ISO 10567.
- Lifting capacity of the Robex Series does not exceed 75% of the tipping load with the machine on firm, level ground or 87% of full hydraulic capacity.
- The load point is a hook located on the back of the bucket.
- (*) indicates the load limited by hydraulic capacity.

STANDARD EQUIPMENT

ISO standard canopy	Engine coolant temperature gauge	Blocked air filter	Electric horn	Arm (0.96 m; 3' 2")
Canopy ROPS (ISO 3471)	Warning	Low fuel level	Battery (1 x 12 V x 80 AH)	Rubber tracks (230 mm, 9")
FOPS (ISO 3449)	Quick coupler	One key fits all	Battery master switch	Single acting piping (Breaker, etc)
TOPS (ISO 12117)	Engine oil pressure	Mechanical suspension seat	Automatic swing brake	Double acting piping (Clamshell, etc)
Centralized monitoring	Engine coolant temperature	with seat belt	Removable reservoir tank	
Gauges	Preheat	Console box tilting system (LH.)	Water separator, fuel line	
Fuel level gauge	Low battery	Two front working lights	Mono boom (1.80 m; 5' 11")	

OPTIONAL EQUIPMENT

Accumulator, work equipment lowering	Travel alarm	Operator suit
	Tool kit	Lever pattern change valve

Dimensions & Working Ranges

R16-9 DIMENSIONS

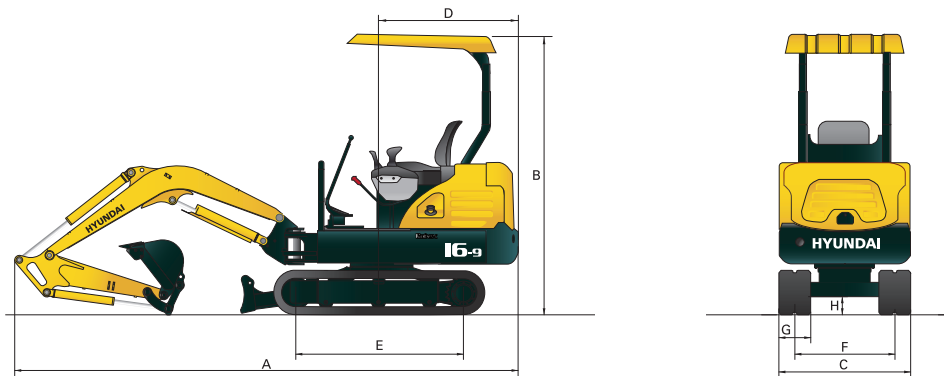

mm (ft-in)

A	Overall length	3,840 (12'7")	E	Tumbler distance	1,230 (4'0")
B	Overall height	2,300 (7'7")	F	Track gauge	750 ~1,020 (2'6" ~ 3'4")
C	Overall width	980 ~1,250 (3'3" ~ 4'1")	G	Track shoe width	230 (0'9")
D	Tail swing radius	1,065 (3'6")	H	Ground clearance	150 (0'6")

R16-9 WORKING RANGES

mm (ft-in)

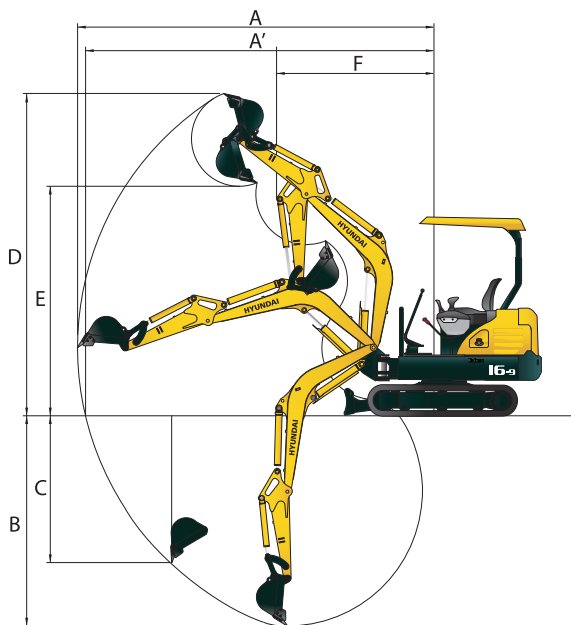

	Boom length	1,800 (5'11")
	Arm length	960 (3'2")
A	Max. digging reach	3,970 (13'0")
A'	Max. digging reach at ground	3,880 (12'9")
B	Max. digging depth	2,250 (7'5")
C	Max. vertical wall digging depth	1,785 (5'10")
D	Max. digging height	3,670 (12'0")
E	Max. dumping height	2,550 (8'4")
F	Min. swing radius	1,615 (5'4")

Standard and optional equipment may vary. Contact your Hyundai dealer for more information. The machine may vary according to international standards. All imperial measurements rounded off to the nearest pound or inch.

PLEASE CONTACT

 **HYUNDAI**
HEAVY INDUSTRIES EUROPE
CONSTRUCTION EQUIPMENT