

We build a better future

Robex
27z-9

Equipped with Tier 3a engine



*Photo may include optional equipment.

Pleasure works

An operator, who takes pleasure in his work, does a better job. That is why we at Hyundai Heavy Industries do everything we can to make that happen. We merged operator preference, fast precision and lasting performance into a quality product. Hyundai's 9 series earthmoving equipment simply makes time fly, makes pleasure work!



*Photo may include optional equipment.

Machine Walk-Around

Robust Upper and Lower Frame

The structure of the upper frame is designed to absorb high stress and to resist inherent external influences. An X-type center frame and a reinforced box section track frame provide exceptional strength and longer service life to withstand tough working conditions.

Engine Technology

Powerful and reliable, Tier 3a / EU stage IIIa certified, fuel efficient Mitsubishi S3L2 engine. Electronically controlled, clean and efficient combustion. Low noise / anti-restart function.

Control System

Control devices are well located for increased operator's comfort and a higher productivity. The operator can easily control the machine in any working condition.

Advanced Hydraulic System

Our new R27Z-9 is equipped with arm flow summation system, boom holding system and swing parking brake for smooth and fine control. Other integrated features are hydraulic damper in travel pedal, swing reducer lubrication by hydraulic oil and leak-free grease chamber of swing bearing.

Comfortable and High-Strength Cabin

The spacious cabin is ergonomically designed, with low noise level and high visibility. Canopy & cabin frame are complying with international standard TOPS, ROPS & FOPS, for maximum protection of the operator.

Operators' Convenience

R27Z-9 cabin equipped with suspension seat, foldable pedals and various storage space for advanced operator comfort. The monitoring system displays warning indicators, water temperature gauge, fuel gauge and hour meter to check the full status of the machine at a single glance.

Easy to Maintain

With open access of doors, covers and engine hoods, air cleaner and centralized grease fittings the machine is a pleasure to maintain.

Extended Life of Components

Long-life hydraulic filters, long-life hydraulic oil, long-lasting shims and long-lasting bushes are reducing operation costs.

Preference

An operator, who sets his machine to his needs, takes pleasure in his work. 9 Series respects operator preference with regards to comfort, ease-of-use and controllability.

Operators can fully customize their work environment and operating preferences to fit their individual needs.



*Photo may include optional equipment.



Dashboard

The dashboard of the R27Z-9 indicates the status of the machine like warnings of engine oil pressure, battery charge, engine coolant temperature and fuel gauges.

Comfortable Operating Cabin

In a 9 series cabin, you can adjust the seat, console and armrests to suit your preferred comfort level.

1. The pedals (travel - boom offset - attachment) are installed in a convenient position and can be folded in to gain extra foot space.
2. Different sizes of cup holders.
3. Operator's belongings can be stored in a lockable storage box under the seat.
4. Armrests to increase operator's comfort.
5. Slidable front window can be opened easily and is kept safely in open position (cabin Type)

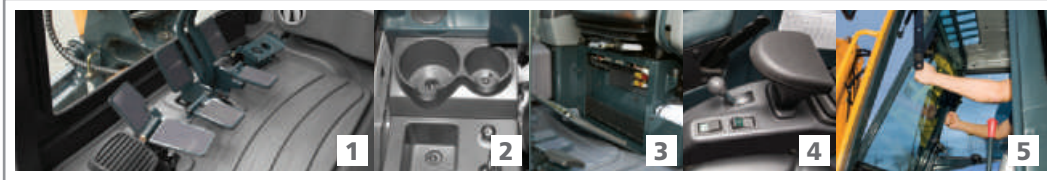

Stressless

Work is stressful enough; your working environment should be stressless. Hyundai's 9 Series provides improved cabin interior and additional storage space to minimize the stress of the operator.

Operator Comfort

The left and right joysticks are ergonomically placed for convenient operation. The joysticks have enough space to install additional option switches. A safety lever is installed to prevent unexpected activation of the hydraulic attachments. When the safety lever is positioned upright, hydraulic functions are disengaged.



A tiltable left-side console make the operator easier to enter and exit the cab.



Precision

An operator, who feels his machine respond smoothly, takes pleasure in his work. 9 Series delivers fast precision by combining smoother hydraulics with wider view and less stress. Innovative hydraulic system technologies make the R27Z-9 excavator fast, smooth and easy to control.



*Photo may include optional equipment.



Offset Boom

With an offset function of the boom from 75° to the left side and 50° to the right side, the zero-tail machine is even more flexible to use on narrow jobsites.

Hydraulic System Improvements

To achieve optimum precision, Hyundai redesigned the hydraulic system to provide the operator with super fine touch and top level controllability.

Newly improved features include arm flow summation system and boom holding system, in order to save energy, prevent against cavitation, increase speed and to avoid the drop of attachments in neutral condition.



Structural Strength

The 9 Series cabin structure is designed with slimmer but stronger tubing for more safety and better visibility. Low-stress and high strength steel is welded to form a strong and stable lower frame. Structural durability is analyzed and tested by FEM-analysis (Finite Elements Method) and long-term durability tests.

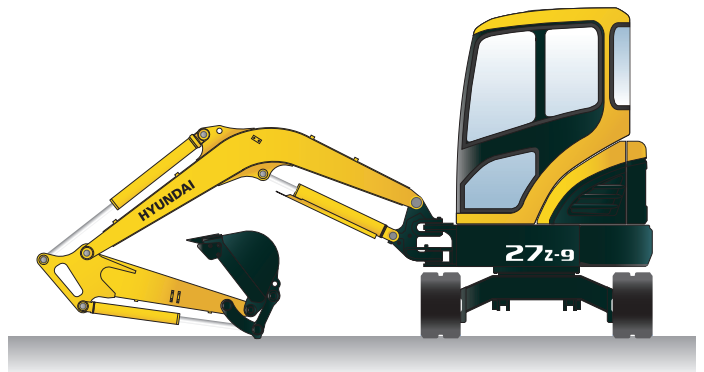

Zero-tail Swing

R27Z-9's short tail swing radius allows the operator work in confined areas like close to buildings on roadways, and in urban areas. This compact radius design provides easy and efficient operation in any limited space work environment.



Mitsubishi S3L2

Tier 3a / EU stage IIIa certified, Mitsubishi S3L2 engine provides maximum power, reduced emissions, reliability and optimum fuel efficiency.

Profitability

An owner, who knows his machine saves money, takes pleasure in owning it. 9 Series excavators contribute to your business as a time, fuel, spare-part and cost saving earthmoving solution.



*Photo may include optional equipment.



Easy Maintenance Access

The R27Z-9 was built with accessibility in mind. All doors, covers and hoods are designed for full open accessibility. The R27Z-9 offers plenty of space to complete regular maintenance.



Easy to Change Air Cleaner

The R27Z-9 is equipped with a durable plastic air cleaner, designed for easy maintenance.

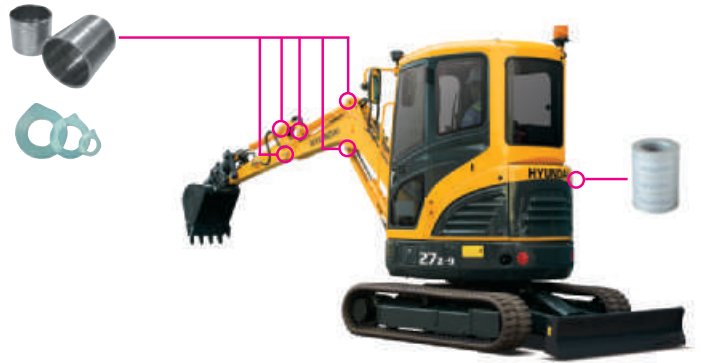

Extended Life of Components

By adopting long-life hydraulic filters (1000 hrs) and long-life hydraulic oil (5000 hrs) operation costs are reduced. Oil change intervals are extended to 250 operating hours because self-lubricating bushes and resin shims are applied.



Centralized Grease Fittings

Centralized grease fittings for faster and easier maintenance.



Cylinder Covers

Cylinders of boom and dozer blade are provided with covers for extra protection.

Specifications

ENGINE

MODEL	MITSUBISHI S3L2		
Type	4 Cycle Diesel engine, 3 cylinders in line, water cooled		
Rated flywheel horse power			
SAE	J1995 (gross)	24.7 HP (18.4 kW) at 2,300 rpm	
	J1349 (net)	23.1 HP (17.2 kW) at 2,300 rpm	
DIN	627 1/1 (gross)	25.0 HP (18.4 kW) at 2,300 rpm	
	627 1/1 (net)	23.1 HP (17.2 kW) at 2,300 rpm	
Max. torque	8.0 kgf.m (58 lbf.ft) at 1,800 rpm		
Bore x stroke	78 mm x 92 mm (3.07" x 3.62")		
Piston displacement	1,318 cc		
Batteries	12V - 80AH		
Starting motor	12V - 1.7kW		
Alternator	12V - 50A		

HYDRAULIC SYSTEM

Main pump	
Type	Two variable displacement piston pumps + gear pump
Rated flow	2 x 27.6 + 19.6 lpm
Pilot pump	Gear pump 10.4 lpm
Hydraulic motors	
Travel	Two speed axial piston motor with counter balance valve and parking brake
Swing	Axial piston motor with automatic brake
Relief valve setting	
Implement circuits	220 Kgf/cm ² (3,270 psi)
Travel circuit	220 Kgf/cm ² (3,270 psi)
Swing circuit	175 Kgf/cm ² (2,490 psi)
Pilot circuit	30 Kgf/cm ² (430 psi)
Service valve	Installed

HYDRAULIC CYLINDERS

No. of cylinder - bore x stroke	
Boom	1 - 75 x 565 mm
Arm	1 - 65 x 500 mm
Bucket	1 - 60 X 420 mm
Boom swing	1 - 75 X 400 mm
Dozer blade	1 - 85 X 140 mm

OPERATOR'S CAB

Noise Levels (dynamic value)	
Outside cabin - LwA	94 dB
Inside cabin - LpA	75 dB

COOLANT & LUBRICANT CAPACITY

(refilling)	liter	US gal	UK gal
Fuel tank	42	11.1	9.2
Engine coolant	4	1.32	1.1
Engine oil	5.9	1.56	1.3
Hydraulic tank	46	12.2	10.1

TRAVEL LEVERS

Traveling and steering: Two levers with foldable pedals.

HYDRAULIC CONTROLS

Type	
Pilot control	Two joysticks with one safety lever (LH): Swing and arm, (RH): Boom and bucket with horn (ISO)
Engine throttle	Mechanical, cable type

SWING SYSTEM

Swing motor	Axial piston motor
Swing reduction	Planetary gear reduction
Swing circuit lubrication	Grease-bathed
Swing brake	Multi wet disc
Swing speed	9 rpm

DRIVES & BRAKES

Max. travel speed (high/low)	4.4 km / 2.4 km (2.8 mph) / (1.6 mph)
Maximum traction force	2.4 ton
Maximum gradeability	30°
Parking brake	Multi wet discs

DIGGING FORCE (ISO)

Bucket	2,050 kgf
	20.1 kN
	4,520 lbf
Arm	1,400 kgf
	13.7 kN
	3,090 lbf

WEIGHT (APPROXIMATE)

Operating weight, including 2,030 mm (6' 8") boom; 1,120 mm (3' 8") arm, SAE heaped 0.08 m³ (0.1 yd³) excavator bucket, lubricant, coolant, full fuel tank, hydraulic tank and the standard equipment.

Shoe Width	Rubber shoes 300 mm (12")	
Operating Weight	Cabin	2,880 Kg (6,350 lb)
	Canopy	2,730 Kg (6,020 lb)
Ground Pressure	Cabin	0.34 kg / cm ² (4.83 psi)
	Canopy	0.32 kg / cm ² (4.55 psi)

UNDERCARRIAGE

X-type center frame is integrally welded with reinforced box-section track frames. The undercarriage includes lubricated rollers, track adjusters with shock absorbing springs, sprockets and rubber shoes.

Center frame	X-leg type
Track frame	Pentagonal box type
No. of carrier roller on each side	1
No. of track roller on each side	3

LIFTING CAPACITIES R27Z-9



Boom : 2.03 m (6' 8") / Arm : 1.12 m (3' 8") / Bucket : 0.08 m³ (0.1 yd³) SAE heaped / Dozer up : 300 mm (12") rubber track with 220kg (485 lb) counterweight

Load point height m (ft)		Load radius								At max. reach		
		2.0 m (6.6 ft)		2.5 m (8.2 ft)		3.0 m (9.8 ft)		3.5 m (11.5 ft)		Capacity		Reach
												m (ft)
3.5 m	kg									*550	460	3.07
11.5 ft	lb									*1210	1010	(10.1)
3.0 m	kg					610	450			460	340	3.63
9.8 ft	lb					1340	990			1010	750	(11.9)
2.5 m	kg					610	450	460	340	380	290	3.99
8.2 ft	lb					1340	990	1010	750	840	640	(13.1)
2.0 m	kg			*790	610	600	450	460	340	350	250	4.22
6.6 ft	lb			*1740	1340	1320	990	1010	750	770	550	(13.8)
1.5 m	kg			800	590	590	440	460	340	320	240	4.35
4.9 ft	lb			1760	1300	1300	970	1010	750	710	530	(14.3)
1.0 m	kg			770	560	580	420	450	330	320	230	4.39
3.3 ft	lb			1700	1230	1280	930	990	730	710	510	(14.4)
0.5 m	kg			750	540	570	410	440	320	320	230	4.35
1.6 ft	lb			1650	1190	1260	900	970	710	710	510	(14.3)
Ground	kg	1080	750	740	530	560	400	440	320	330	240	4.22
Line	lb	2380	1650	1630	1170	1230	880	970	710	730	530	(13.8)
-0.5 m	kg	1080	750	740	530	550	400	440	320	360	260	4.00
-1.6 ft	lb	2380	1650	1630	1170	1210	880	970	710	790	570	(13.1)
-1.0 m	kg	1090	760	740	530	560	400			420	300	3.64
-3.3 ft	lb	2400	1680	1630	1170	1230	880			930	660	(11.9)
-1.5 m	kg	1110	780	760	550					550	400	3.09
-4.9 ft	lb	2450	1720	1680	1210					1210	880	(10.1)
-2.5 m	kg									*450	420	3.06
-8.2 ft	lb									*990	930	(10.0)

Boom : 2.03 m (6' 8") / Arm : 1.12 m (3' 8") / Bucket : 0.08 m³ (0.1 yd³) SAE heaped / Dozer down : 300 mm (12") rubber track with 220kg (485 lb) counterweight

Load point height m (ft)		Load radius								At max. reach		
		2.0 m (6.6 ft)		2.5 m (8.2 ft)		3.0 m (9.8 ft)		3.5 m (11.5 ft)		Capacity		Reach
												m (ft)
3.5 m	kg									*550	490	3.07
11.5 ft	lb									*1210	1080	(10.1)
3.0 m	kg					*640	480			*550	360	3.63
9.8 ft	lb					*1410	1060			*1210	790	(11.9)
2.5 m	kg					*640	490	*570	370	*570	310	3.99
8.2 ft	lb					*1410	1080	*1260	820	*1260	680	(13.1)
2.0 m	kg			*790	650	*720	480	*680	370	*570	270	4.22
6.6 ft	lb			*1740	1430	*1590	1060	*1500	820	*1260	600	(13.8)
1.5 m	kg			*1020	630	*830	470	*730	360	*570	260	4.35
4.9 ft	lb			*2250	1390	*1830	1040	*1610	790	*1260	570	(14.3)
1.0 m	kg			*1260	600	*960	450	*800	350	*600	250	4.39
3.3 ft	lb			*2780	1320	*2120	990	*1760	770	*1320	550	(14.4)
0.5 m	kg			*1410	580	*1050	440	*850	350	*630	250	4.35
1.6 ft	lb			*3110	1280	*2310	970	*1870	770	*1390	550	(14.3)
Ground	kg	*1490	810	*1460	570	*1090	430	*860	340	*650	260	4.22
Line	lb	*3280	1790	*3220	1260	*2400	950	*1900	750	*1430	570	(13.8)
-0.5 m	kg	*1990	810	*1420	570	*1070	430	*810	340	*660	280	4.00
-1.6 ft	lb	*4390	1790	*3130	1260	*2360	950	*1790	750	*1460	620	(13.1)
-1.0 m	kg	*1740	820	*1260	570	*930	440			*660	330	3.64
-3.3 ft	lb	*3840	1810	*2780	1260	*2050	970			*1460	730	(11.9)
-1.5 m	kg	*1290	840	*910	590					*620	430	3.09
-4.9 ft	lb	*2840	1850	*2010	1300					*1370	950	(10.1)
-2.5 m	kg									*450	*450	3.06
-8.2 ft	lb									*990	*990	(10.0)

- Lifting capacity is based on SAE J1097, ISO 10567.
- Lifting capacity of the Robex Series does not exceed 75% of the tipping load with the machine on firm, level ground or 87% of full hydraulic capacity.
- The load point is a hook located on the back of the bucket.
- (*) indicates the load limited by hydraulic capacity.

STANDARD EQUIPMENT

ISO standard cabin	· Lockable door	Engine coolant temperature	· Console box tilting system (LH.)	· Mono boom (2.03 m; 6' 8")
· Canopy ROPS (ISO 3471)	· Accessory box & Ash-tray	Preheat engine	· Two front working lights	· Arm (1.12 m; 3' 8")
FOPS (ISO 3449)	· Centralized monitoring	Low battery	· Electric horn	· Rubber shoes (300 mm; 12")
TOPS (ISO 12117)	· Gauges	Air cleaner clogging	· Battery (1 x 12 V x 80 AH)	· Single acting piping (Breaker, etc)
· All-weather steel cab with all-around visibility	Fuel level gauge	Fuel empty	· Battery master switch	· Double acting piping (Clamshell, etc)
· Safety glass windows	Engine coolant temperature gauge	· Door and locks, one key fits all	· Automatic swing brake	
· Sliding fold-in front window	· Warning lamps	· AM/FM radio and cassette	· Removable reservoir tank	
· Sliding side window	Quick clamp	· Mechanical suspension seat with seat belt	· Water separator, fuel line	
	Engine oil pressure		· Counterweight (220 kg; 485 lb)	

OPTIONAL EQUIPMENT

ISO standard canopy	· Beacon lamp	· Quick coupler	· Heater & Defroster
· Cabin ROPS (ISO 3471)	· Accumulator, work equipment lowering	· Tool kit	· Lever Pattern Change Valve
FOPS (ISO 3449)	· Travel alarm	· Operator suit	
TOPS (ISO 12117)			

Dimensions & Working Ranges

R27Z-9 DIMENSIONS

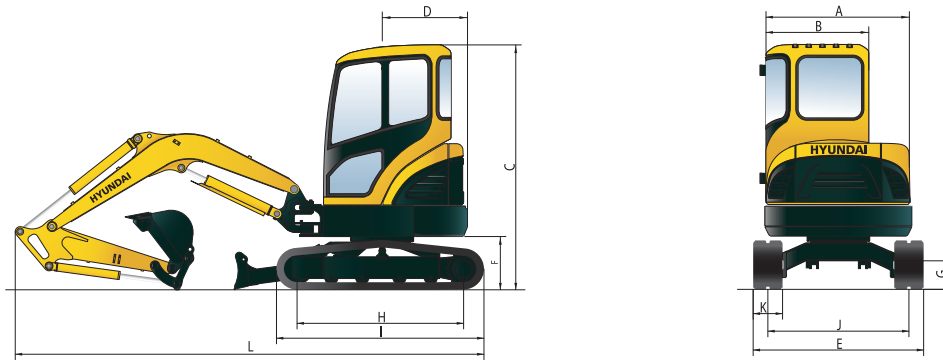

ITEM	R27Z-9	ITEM	R27Z-9
(A) Overall width of upper structure	1,485 mm	(G) Ground clearance	290 mm
(B) Overall width of cab	1,050 mm	(H) Tumbler distance	1,550 mm
(C) Overall height of cab	2,500 mm	(I) Track length	1,970 mm
(D) Tail swing radius	775 mm	(J) Track gauge	1,250 mm
(E) Overall width	1,550 mm	(K) Track shoe width	300 mm
(F) Clearance under counterweight	540 mm	(L) Overall length	4,180 mm

R27Z-9 WORKING RANGES

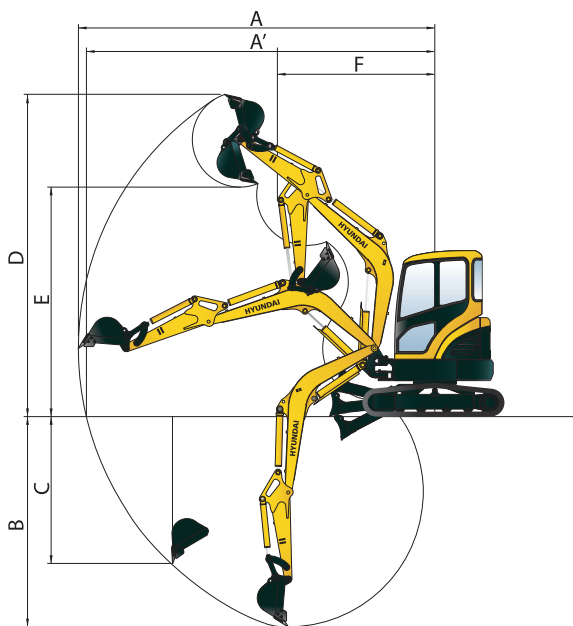

Boom length	2,030 mm
Arm length	1,120 mm
(A) Max. digging reach	4,650 mm
(A') Max. digging reach at ground	4,515 mm
(B) Max. digging depth	2,500 mm
(C) Max. vertical wall digging depth	2,085 mm
(D) Max. digging height	4,270 mm
(E) Max. dumping height	2,890 mm
(F) Min. front swing radius	2,055 mm

Standard and optional equipment may vary. Contact your Hyundai dealer for more information. The machine may vary according to international standards. All imperial measurements rounded off to the nearest pound or inch.

PLEASE CONTACT

 **HYUNDAI**
HEAVY INDUSTRIES EUROPE
CONSTRUCTION EQUIPMENT